



ITT



Triplex Sales
1-847-839-8442
www.triplexsales.com

Pure-Flo[®] Zero Static with Upstream Sample and Downstream Purge (ZUD)

The Zero Static Upstream Sample and Downstream Purge valve allows for point of use sampling of the upstream flow, purging and sterilization of the downstream process, and sampling from the same Zero Static valve.

Typical Applications

- A single use point with multiple outlets for purging and steam sterilization of the downstream line and sampling of the upstream line

Specifications

Standard Sizes:

- 0.5" - 4" (DN 15 - 100) Main Valve size
- 0.5" - 4" (DN 15 - 50) Run size
- 0.5" BT Sample valve*
- 0.5" PF Purge valve
- Other sizes available upon request

Materials:

- 316L ASTM - A479
- DN 177440, 1.4435
- AL6XN
- Hastelloy C-22 & C-276
- Other materials available upon request

Standard End Connections:

- 14, 16, 18, 20 Gauge OD tubing
- DIN/ISO
- Tri-Clover Tri-Clamp[®]
- Others available upon request

End Connections:

- P4 as standard is 0.75" Tri-Clamp connection
 - P5 as standard is 0.5" Tri-Clamp connection
- Compatible with standard Pure-Flo topworks: See PFTOP for details on available manual bonnets or actuator.

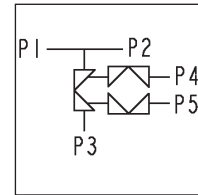
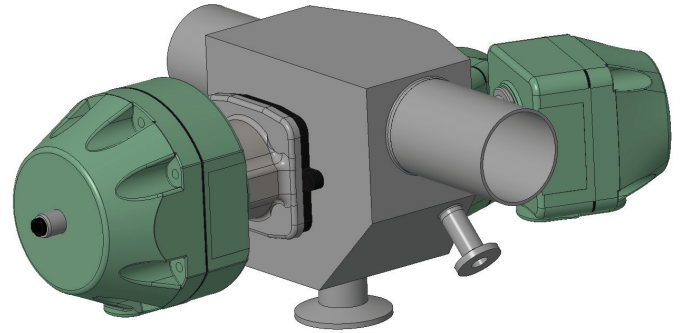

Flow Path

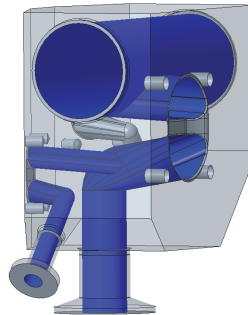

Purge

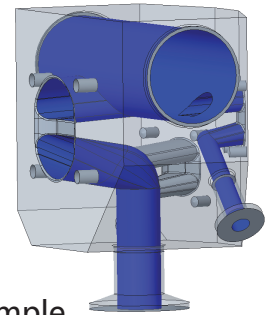

Sample



Sample outlet features a reducing ferrule (.75" connection to a .5" port) to maximize drainability of the small diameter port.



How to Order a Zero Static with Upstream Sample and Downstream Purge

1" ZUD wrought stainless steel body with 0.5" Bio-Tek Upstream Sample (right side) and 0.5" Pure-Flo Downstream Purge. Tri-Clamp main valve end connection. 2" Zero Static tube size with 16 ga buttweld ends. (Sample valve with 0.75" reducing ferrule and purge valve with 0.5" Tri-Clamp end connection.) 25 Ra interior finish, standard exterior finish (Scotch Brite).

Figure Number: ZUD-1-419-2-428-.5-SVBT-419R-R-.5-TVPF-419-W-6-1-0

Configuration Example		ZUD	1	419	2		428	.5	SVBT	419R	R	.5	TVPF	419	W	6-1-0
Valve Body	Block Type	ZUD														
	Main Valve Size		1													
	Main Valve End Connection (P3)			419												
	Zerostatic Tube Size				2											
	U-Bend Orientation ¹															
	Zerostatic Tube End Connections (P1, P2)						428									
	Second Valve Size							.5								
	Second Valve Type (.5" only) ¹								SVBT							
	Second Valve End Connection (P4) ³									419						
	Second Valve Outlet Orientation										R					
	Third Valve Size											.5				
	Third Valve Type (.5" only) ¹												TVPF			
	Third Valve End Connection (P5)													419		
	Body Material														W	
Polish Selections																6-1-0

¹ For a U-Bend Vertical Tube, enter VV. For Horizontal Tube, enter HV. See drawings below for vertical tube and horizontal tube examples.

² For .5 inch valve, must specify Pure-Flo (PF) or Bio-Tek (BT). PF is recommended for steam applications. .5" sample port is available upon request.

³ 419R refers to .75 x .5 reducing Tri-Clamp port connection required for drainability.

Note: All second and third valve options shown above are standard.

To add topworks, see BBTOP. For additional figure numbers, see PFORD.

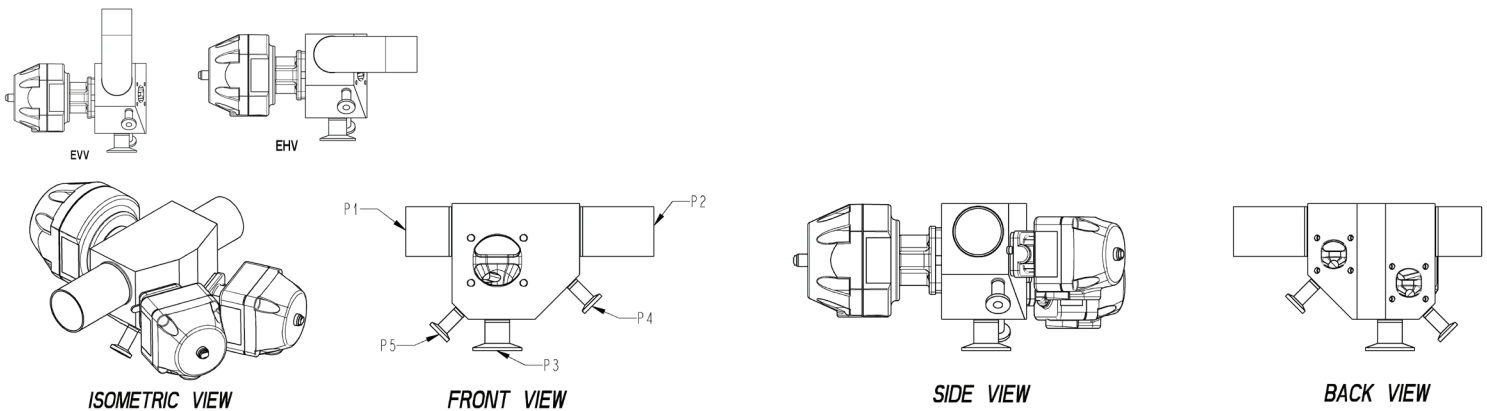

Please contact ITT Engineered Valves for the latest drawing and dimensional information. The above drawing should only be used as a general reference.

ITT Engineered Valves
33 Centerville Road
Lancaster, PA 17603, USA
Tel: +1 (717) 509-2200

Cam-Line, Cam-Tite, Dia-Flo,
EnviZion, Pure-Flo, Skotch

ITT Engineered Valves
1110 Bankhead Avenue
Amory, MS 38821, USA
Tel: +1 (662) 256-7185

Fabri-Valve

ITT Bornemann GmbH
31683 Obernkirchen
Germany
Tel: +49 5724 390-0

EnviZion, Pure-Flo